



# microFIT Project Connection Application

Reference Number: \_\_\_\_\_

(For GHESI Internal Use, WO/JO: \_\_\_\_\_)

This form is applicable to *microFIT* projects with a total nameplate rating of 10 kW or less, generating electricity from a renewable energy source.

A Connection Impact Assessment will not be required for *microFIT* projects. There may be a limitation on the number of micro-generation facilities that can be connected to the same distribution feeder.

The Applicant is responsible for all costs related to the connection of the *microFIT* project to the distribution system including, but not limited to, meter, meter installation, and connection labour.

**Please return the completed application form by email, mail or fax to:**

Guelph Hydro Electric Systems Inc.  
Engineering Department  
395 Southgate Drive,  
Guelph, Ontario, N1G 4Y1  
Email: microfitprogram@guelphhydro.com  
Fax: 519-822-4963

**IMPORTANT:** All fields below are mandatory, except where noted. Incomplete applications may be returned by Guelph Hydro Electric Systems Inc. (Guelph Hydro). Applicants are cautioned to not incur major expenses until Guelph Hydro approves the connection of the proposed generation facility.

- 1. **Date of Connection Application to Guelph Hydro:** \_\_\_\_\_
- Date of Contract Application to OPA:** \_\_\_\_\_
- microFIT Reference Number:** \_\_\_\_\_
- Proposed In-Service Date:** \_\_\_\_\_

**2. Project Information:**

**Applicant (Owner)**

Company / Person: \_\_\_\_\_

Contact: \_\_\_\_\_

Mailing Address: \_\_\_\_\_

Telephone: \_\_\_\_\_

Fax: \_\_\_\_\_

E-mail: \_\_\_\_\_

**Consultant / Contractor**

Company / Person: \_\_\_\_\_

Contact: \_\_\_\_\_

Mailing Address: \_\_\_\_\_

Telephone: \_\_\_\_\_

Fax: \_\_\_\_\_

E-mail: \_\_\_\_\_

**3. Customer Status:**

Existing Guelph Hydro Customer?  Yes  No  
If yes, Guelph Hydro 18-digit Account Number: \_\_\_\_\_ - \_\_\_\_\_  
Name of Account Holder: \_\_\_\_\_  
Are you a GST registrant?  Yes  No  
If yes, provide your GST registration number: \_\_\_\_\_ RT \_\_\_\_\_

**4. Project Location:**

Project Name \_\_\_\_\_  
Address \_\_\_\_\_  
City / Town \_\_\_\_\_  
GPS Co-ordinates: Latitude: \_\_\_\_\_ Longitude: \_\_\_\_\_

**5. Connection to Guelph Hydro’s Distribution System:**

a. Connection voltage to Guelph Hydro’s distribution system: \_\_\_\_\_  
b. Station: \_\_\_\_\_  
c. Feeder: \_\_\_\_\_

**6. Fuel Type:**

Wind Turbine  Hydraulic Turbine  
 Solar / Photovoltaic Cells (Rooftop)  Solar / Photovoltaic Cells (Ground Mount)  
 Biomass  Bio-diesel  
 Bio-gas  Other, please specify \_\_\_\_\_

**7. Project Size:**

Generator connection  Single phase  Three phase  
Metering configuration (refer to Appendix A)  Parallel

*If microFIT project is solar PV*

Existing Total Nameplate Capacity \_\_\_\_\_ kW Panels \_\_\_\_\_ kW Inverters  
Number of \_\_\_\_\_ Panels \_\_\_\_\_ Inverters  
Nameplate Capacity of PV Panel \_\_\_\_\_ kW / Panel \_\_\_\_\_ kW Total  
Nameplate Capacity of Inverter \_\_\_\_\_ kW / Inverter \_\_\_\_\_ kW Total  
Total nameplate Capacity\* \_\_\_\_\_ kW Panels \_\_\_\_\_ kW Inverters

*\*(If microFIT project is an expansion to an existing PV system)*

*For all other microFIT projects*

Existing Total Nameplate Capacity \_\_\_\_\_ kW  
Number of Additional Units \_\_\_\_\_  
Nameplate Rating of Each Unit \_\_\_\_\_ kW  
Proposed Total Nameplate Capacity \_\_\_\_\_ kW

**Note: the Applicant is responsible to ensure the generation output is configured to match Guelph Hydro’s distribution system configuration.**

In order to finalize the Project Connection Application, the Applicant must supply a Single Line Diagram acceptable to Guelph Hydro, following the template provided in attached Appendix A. In addition to the items shown in the attached template, the Single Line Diagram must include the following information where applicable:

**8. Generator / Solar PV Panel / Inverter Information:**

- a. Manufacturer
- b. Model Number
- c. Number of phases (Single Phase / Three Phase)
- d. Nameplate rating (kW)
- e. Generator / Inverter AC output voltage (Volts)

**9. Other Electrical Components:**

- a. Show all relevant electrical components (breakers, panels, splitters, disconnect switches, etc) to Guelph Hydro grid connection point. **(See appendix B)**

**10. Customer Owned Interface Transformer (if applicable):**

For generation facilities installing more than one type of generator, or where required to ensure the generation output is configured to match Guelph Hydro's distribution system configuration, include the following information:

- a. Transformer rating (kVA)
- b. Primary and Secondary Winding Connection (Delta / Star)
- c. Primary and Secondary Voltages

**11. Required Labeling:**

Please see attached diagram in Appendix B for GHESI's requirements for labeling of the meter bases and disconnects. These are additional to ESA's requirements.

***By submitting this form, the Applicant authorizes Guelph Hydro Electric Systems Inc. to collect the information set out in this and related documents, collected in accordance with the terms hereof, the terms of Guelph Hydro's Conditions of Service, Guelph Hydro's Privacy Policy and the requirements of the Distribution System Code and the use of such information for the purposes of the connection of the generation facility to Guelph Hydro's distribution system.***

## SINGLE LINE DIAGRAM - TYPICAL PARALLEL CONFIGURATION

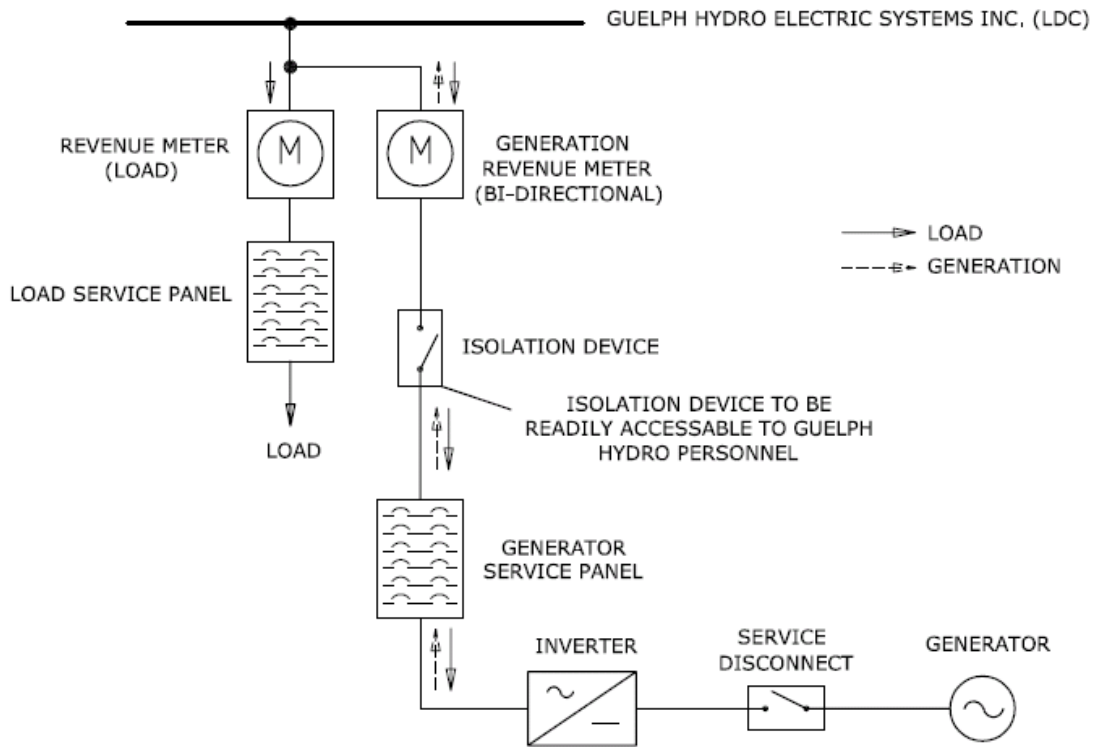

## SINGLE LINE DIAGRAM - TYPICAL SERIES CONFIGURATION

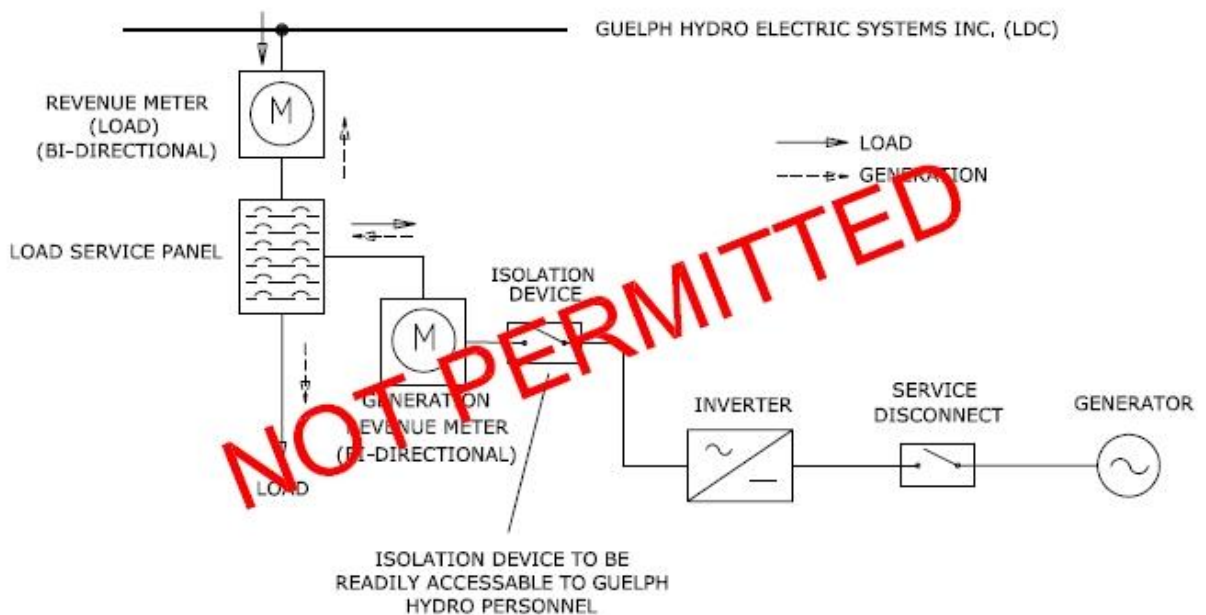

## Single Line Diagram Requirements:

A detailed Single Line Diagram (SLD) is required to illustrate the connection method to Guelph Hydro's distribution network.

The single line diagram should include the following information:

- Address of the distributed generation (DG) installation
- Contact Information
- Nameplate capacity (panels and inverter)
- Current rating of the fused disconnect switch
- High-level specification of all the components (part numbers and manufacturer), especially for three-phase installations
- Output voltage to the distribution network

Single phase inverters are not allowed in three phase generation connection. Only three phase inverters are allowed in three phase generation connection.

In addition, in case of a three phase inverter based installation, a delta/wye-gnd transformer is required for DG interconnection and the reasons are explained in the below section.

**Note:** Make sure that the SLD has all the information requested in order for the connection work to be processed.

## DG Interconnection Transformer:

An interconnection transformer is used to provide the necessary isolation required between the DG and the distribution network. They are also used for the following reasons:

- To eliminate possible zero sequence or dc components in the generated voltages
- To increase the protection on both the utility and DG side
- To ensure accuracy of metering on generation service
- The transformer can be utilized as filter inductor to improve the output current quality of the DG unit

A delta (DG)/wye-gnd (distribution network) transformer would allow for the above conditions to be satisfied, in case of a three phase inverter based installation.

**Appendix B – Typical Residential MicroFIT Meter Base Arrangement**

